

Sleeve-Alls are pre-assembled expanding sleeve anchors for use in all types of solid base materials. These anchors are available in acorn, hex, rod coupler, flat or round head styles for a wide range of applications.

MATERIAL: Carbon and stainless steel

FINISH: Carbon Steel: Zinc plated

INSTALLATION:

⚠ Caution: Oversized holes will make it difficult to set the anchor and will reduce the anchor's load capacity.

- Drill a hole in the base material using a carbide drill bit the same diameter as the nominal diameter of the anchor to be installed. Drill the hole to the specified embedment depth and blow it clean using compressed air. Overhead installations need not be blown clean. Alternatively, drill the hole deep enough to accommodate embedment depth and dust from drilling.
- Place the anchor in the fixture and drive into the hole until the washer and nut are tight against fixture.
- Tighten to required installation torque.

CODES: Florida FL 5415.2; Dade County, FL 01-0820.06; Factory Mutual 3017082, 3/8" - 5/8" hex nut; Underwriters Laboratories File Ex3605, 3/8" - 5/8" hex nut. Meets requirements of Federal Specifications A-A-1922A.

⚠ The Load Tables list values based upon results from the most recent testing and may not reflect those in the current code reports. Where code jurisdictions apply, consult the current reports for applicable load values.

SUGGESTED SPECIFICATIONS:

Sleeve Anchors shall be zinc plated studs having a minimum 50,000 psi tensile strength with an expansion sleeve meeting AISI 1008 cold rolled steel or type 304 stainless steel stud with a type 304 stainless steel expansion sleeve, as called for on the drawings. Sleeve anchors shall meet Federal Specifications A-A-1922A. Anchors shall be Sleeve-Alls from Simpson Strong-Tie, Pleasanton, CA. Anchors shall be installed following Simpson Strong-Tie's instructions for Sleeve-Alls.

SLEEVE-ALL™



Acorn



Hex



Flat (Phillips Head)



Round



Rod Coupler

Sleeve-All Installation Sequence

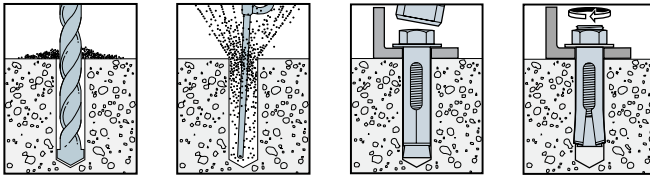

Material Specifications

Anchor Component	Zinc Plated Carbon Steel	304 Stainless Steel
Anchor Body	Material meets minimum 50,000 psi tensile	Type 304
Sleeve	SAE J403, Grade 1008 Cold Rolled Steel	Type 304
Nut	Commercial Grade, meets requirements of ASTM A 563 Grade A	Type 304
Washer	SAE J403, Grade 1008/1010 Cold Rolled Steel	Type 304

Sleeve-All Installation Data

Sleeve-All Dia. (in)	1/4	5/16	3/8	1/2	5/8	3/4
Bit Size (in)	1/4	5/16	3/8	1/2	5/8	3/4
Wrench Size ¹ (in)	3/8	7/16	1/2	9/16	3/4	15/16
Wrench Size for Coupler Nut (in)			1/2	5/8	3/4	—

1. Applies to Acorn and Hex head configurations only.

Length Identification Head Marks on Sleeve-All Anchors (corresponds to length of anchor – inches).

Mark	A	B	C	D	E	F	G	H	I	J	K	L	M	N	O	P	Q	R	S	T	U	V	W	X	Y	Z
From	1½	2	2½	3	3½	4	4½	5	5½	6	6½	7	7½	8	8½	9	9½	10	11	12	13	14	15	16	17	18
Up To But Not Including	2	2½	3	3½	4	4½	5	5½	6	6½	7	7½	8	8½	9	9½	10	11	12	13	14	15	16	17	18	19

SLEEVE-ALL® Sleeve Anchors

Sleeve-All Product Data - Zinc Plated Carbon Steel

Size (in)	Model No.	Head Style	Bolt Diameter - Threads per inch	Max. Fixture Thickness (in)	Quantity	
					Box	Ctn
1/4 x 1 3/8	SL25138A	Acorn Head	3/16 - 24	1/4	100	500
1/4 x 2 1/4	SL25214A			1 1/8	100	500
5/16 x 1 1/2*	SL31112H	Hex Head	1/4 - 20	3/8	100	500
5/16 x 2 1/2	SL31212H			1 1/16	50	250
3/8 x 1 7/8	SL37178H		5/16 - 18	3/8	50	250
3/8 x 3	SL37300H			1 1/2	50	200
3/8 x 4	SL37400H		3/8 - 16	2 1/4	50	200
1/2 x 2 1/4*	SL50214H			1/2	50	200
1/2 x 3	SL50300H		1/2 - 13	3/4	25	100
1/2 x 4	SL50400H			1 3/4	25	100
1/2 x 6	SL50600H		5/8 - 11	3 3/8	20	80
5/8 x 2 1/4*	SL62214H			1/2	25	100
5/8 x 3	SL62300H	3/16 - 24	3/4	20	80	
5/8 x 4 1/4	SL62414H		1 1/2	10	40	
5/8 x 6	SL62600H	1/4 - 20	3 1/4	10	40	
3/4 x 2 1/2*	SL75212H		1/2	10	40	
3/4 x 4 1/4	SL75414H	5/16 - 18	7/8	10	40	
3/4 x 6 1/4	SL75614H		2 7/8	5	20	
1/4 x 2	SL25200PF	Phillips Flat Head	3/16 - 24	7/8	100	500
1/4 x 3	SL25300PF			1 7/8	50	250
5/16 x 2 1/2	SL31212PF	1/4 - 20	1/4 - 20	1 1/16	50	250
5/16 x 3 1/2	SL31312PF			2 1/16	50	250
3/8 x 2 3/4	SL37234PF	5/16 - 18	5/16 - 18	1 1/4	50	200
3/8 x 4	SL37400PF			2 1/2	50	200
3/8 x 5	SL37500PF	3/16 - 24	3/16 - 24	3 1/2	50	200
3/8 x 6	SL37600PF			4 1/2	50	200
1/4 x 2	SL25200R	Round Head	3/16 - 24	7/8	100	500
1/4 x 2 3/4	SL25234R			1 5/8	50	250
3/8 x 2 1/2	SL37212R	5/16 - 18	5/16 - 18	1	50	200
3/8 x 3 3/4	SL37334R			2 1/4	50	200
3/8 x 4 3/4	SL37434R			3 1/4	50	200

*These models do not meet minimum embedment requirements for rated load values.

Sleeve-All Product Data - Stainless Steel

Size (in)	Model No.	Head Style	Bolt Dia. Thread (per in)	Max. Fixture Thickness (in)	Quantity	
					Box	Ctn
1/4 x 2 1/4	SL25214FSS	Flat Head	3/16 - 24	1 1/8	100	500
3/8 x 1 7/8	SL37178HSS	Hex Head	5/16 - 18	3/8	50	250
3/8 x 3	SL37300HSS			1 1/2	50	200
1/2 x 3	SL50300HSS		3/8 - 16	3/4	25	100
1/2 x 4	SL50400HSS			1 3/4	25	100

Rod Coupler Product Data - Zinc Plated Carbon Steel

Size (in)	Model No.	Accepts Rod Dia. (in)	Quantity	
			Box	Ctn
3/8 x 1 7/8	SL37178C	3/8	50	200
1/2 x 2 1/4	SL50214C	1/2	25	100
5/8 x 2 1/4	SL62214C	5/8	20	80

Mechanical Anchors

Tension and Shear Loads for 3/8" Sleeve-All Anchor in Grout-Filled CMU (Anchor Installed in Horizontal Mortar Joint or Face Shell)



Size in. (mm)	Embed. Depth in. (mm)	Min. Edge Dist. in. (mm)	Min. End Dist. in. (mm)	Min. Spacing in. (mm)	Tension Load		Shear Load		Install. Torque ft-lbs (N-m)
					Ultimate lbs. (kN)	Allow. lbs. (kN)	Ultimate lbs. (kN)	Allow. lbs. (kN)	
3/8 (9.5)	1 1/2 (38)	16 (406)	16 (406)	24 (610)	2,000 (8.9)	500 (2.2)	2,300 (10.2)	575 (2.6)	15 (20)

- The tabulated allowable loads are based on a safety factor of 4.0 for installations under the UBC. For installations under the IBC and IRC, use a safety factor of 5.0 (multiply the tabulated allowable loads by 0.80).
- Listed loads may be applied to installations through a face shell with the following placement guidelines:
 - Minimum 3" from vertical mortar joint.
 - Minimum 1" from vertical cell centerline.
- Values for 6 and 8-inch wide CMU Grade N, Type II, lightweight, medium-weight and normal-weight concrete masonry units conforming to UBC Standard 21-4 or ASTM C90. The masonry units must be fully grouted with grout complying with UBC Section 2103.4, or IBC Section 2103.12. Mortar is prepared in accordance with Section 2103.3 of the UBC and UBC Standard 21-15, or IBC Section 2103.8. The minimum specified compressive strength of masonry, f'_m , at 28 days is 1,500 psi.
- Embedment depth is measured from the outside face of the concrete masonry unit.
- Drill bit diameter used in base material corresponds to nominal anchor diameter.
- Allowable loads may not be increased for short-term loading due to wind or seismic forces.

*See page 7 for an explanation of the load table icons

Horizontal Mortar Joint/Face Shell Installation

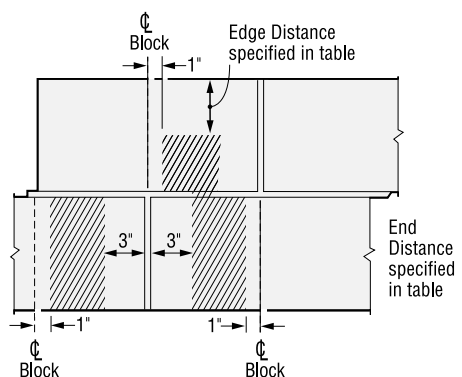

Allowable Anchor Placement in grout filled CMU shown by shaded areas.

Tension and Shear Loads for Sleeve-All Anchors in Normal-Weight Concrete



Size in. (mm)	Embed. Depth in. (mm)	Critical Edge Dist. in. (mm)	Critical Spacing Dist. in. (mm)	Tension Load						Shear Load			Install. Torque ft-lbs (N-m)
				f'c >= 2000 psi (13.8 MPa) Concrete			f'c >= 4000 psi (27.6 MPa) Concrete			f'c >= 2000 psi (13.8 MPa) Concrete			
				Ultimate lbs. (kN)	Std. Dev. lbs. (kN)	Allow. lbs. (kN)	Ultimate lbs. (kN)	Std. Dev. lbs. (kN)	Allow. lbs. (kN)	Ultimate lbs. (kN)	Std. Dev. lbs. (kN)	Allow. lbs. (kN)	
1/4 (6.4)	1 1/8 (29)	2 1/2 (64)	4 1/2 (114)	880 (3.9)	94 (0.4)	220 (1.0)	1,320 (5.9)	189 (0.8)	330 (1.5)	1,440 (6.4)	90 (0.4)	360 (1.6)	5 (7)
5/16 (7.9)	1 7/16 (37)	3 1/8 (79)	5 3/4 (146)	1,120 (5.0)	113 (0.5)	280 (1.2)	1,320 (5.9)	350 (1.6)	330 (1.5)	2,160 (9.6)	113 (0.5)	540 (2.4)	8 (11)
3/8 (9.5)	1 1/2 (38)	3 3/4 (95)	6 (152)	1,600 (7.1)	294 (1.3)	400 (1.8)	2,680 (11.9)	450 (2.0)	670 (3.0)	3,080 (13.7)	223 (1.0)	770 (3.4)	15 (20)
1/2 (12.7)	2 1/4 (57)	5 (127)	9 (229)	3,160 (14.1)	254 (1.1)	790 (3.5)	4,760 (21.2)	485 (2.2)	1,190 (5.3)	5,000 (22.2)	473 (2.1)	1,250 (5.6)	25 (34)
5/8 (15.9)	2 3/4 (70)	6 1/4 (159)	11 (279)	4,200 (18.7)	681 (3.0)	1,050 (4.7)	6,160 (27.4)	1,772 (7.9)	1,540 (6.9)	8,520 (37.9)	713 (3.2)	2,130 (9.5)	50 (68)
3/4 (19.1)	3 3/8 (86)	7 1/2 (191)	13 1/2 (343)	6,400 (28.5)	665 (3.0)	1,600 (7.1)	9,520 (42.3)	674 (3.0)	2,380 (10.6)	10,040 (44.7)	955 (4.2)	2,510 (11.2)	90 (122)

1. The tabulated allowable loads are based on a safety factor of 4.0 for installations under the UBC. For installations under the IBC and IRC, use a safety factor of 5.0 (multiply the tabulated allowable loads by 0.80).
2. Allowable loads may not be increased for short-term loading due to wind or seismic forces.
3. Refer to allowable load adjustment factors for spacing and edge distance on page 134.
4. Drill bit diameter used in base material corresponds to nominal anchor diameter.
5. Allowable tension loads may be linearly interpolated between concrete strengths listed.
6. The minimum concrete thickness is 1 1/2 times the embedment depth.

Tension and Shear Loads for Sleeve-All Anchors in Grout Filled CMU



Size in. (mm)	Embed. Depth in. (mm)	Min. Edge in. (mm)	Min. End Dist. in. (mm)	Min. Spacing in. (mm)	Tension Load		Shear Load		Install. Torque ft-lbs (N-m)
					Ultimate lbs. (kN)	Allow. lbs. (kN)	Ultimate lbs. (kN)	Allow. lbs. (kN)	
Anchor Installed in a Single Face Shell									
3/8 (9.5)	1 1/2 (38)	12 (305)	12 (305)	24 (610)	1,746 (7.8)	435 (1.9)	2,871 (12.8)	720 (3.2)	15 (20)
1/2 (12.7)	2 1/4 (57)	12 (305)	12 (305)	24 (610)	3,384 (15.1)	845 (3.8)	5,670 (25.2)	1,415 (6.3)	25 (34)
5/8 (15.9)	2 3/4 (70)	12 (305)	12 (305)	24 (610)	3,970 (17.7)	995 (4.4)	8,171 (36.3)	2,045 (9.1)	50 (68)
3/4 (19.1)	3 3/8 (86)	12 (305)	12 (305)	24 (610)	6,395 (28.4)	1,600 (7.1)	12,386 (55.1)	3,095 (13.8)	90 (122)
Anchor Installed in Mortar "T" Joint									
3/8 (9.5)	1 1/2 (38)	8 (203)	8 (203)	24 (610)	1,927 (8.6)	480 (2.1)	3,436 (15.3)	860 (3.8)	15 (20)
1/2 (12.7)	2 1/4 (57)	8 (203)	8 (203)	24 (610)	3,849 (17.1)	960 (4.3)	5,856 (26.0)	1,465 (6.5)	25 (34)
5/8 (15.9)	2 3/4 (70)	8 (203)	8 (203)	24 (610)	4,625 (20.6)	1,155 (5.1)	7,040 (31.3)	1,760 (7.8)	50 (68)
3/4 (19.1)	3 3/8 (86)	8 (203)	8 (203)	24 (610)	5,483 (24.4)	1,370 (6.1)	7,869 (35.0)	1,965 (8.7)	90 (122)

*See page 7 for an explanation of the load table icons

1. The tabulated allowable loads are based on a safety factor of 4.0 for installations under the UBC. For installations under the IBC and IRC, use a safety factor of 5.0 (multiply the tabulated allowable loads by 0.80).
2. Listed loads may be applied to installations through a face shell with the following placement guidelines:
 - a. Minimum 3" from vertical mortar joint.
 - b. Minimum 1" from vertical cell centerline.
3. Values for 6 and 8-inch wide CMU Grade N, Type II, lightweight, medium-weight and normal-weight concrete masonry units conforming to UBC Standard 21-4 or ASTM C90. The masonry units must be fully grouted with grout complying with UBC Section 2103.4, or IBC Section 2103.12. Mortar is prepared in accordance with Section 2103.3 of the UBC and UBC Standard 21-15, or IBC Section 2103.8. The minimum specified compressive strength of masonry, f_m, at 28 days is 1,500 psi.
4. Embedment depth is measured from the outside face of the concrete masonry unit.
5. Drill bit diameter used in base material corresponds to nominal anchor diameter.
6. Allowable loads may not be increased for short-term loading due to wind or seismic forces.

SLEEVE-ALL® Technical Information

**Load Adjustment Factors for Sleeve-All Anchors in Normal-Weight Concrete:
Edge Distance and Spacing, Tension and Shear Loads**

How to use these charts:

1. The following tables are for reduced Edge Distance and Spacing.
2. Locate the anchor size to be used for either a tension and/or shear load application.
3. Locate the edge distance (C_{act}) or spacing (S_{act}) at which the anchor is to be installed.
4. The load adjustment factor (f_c or f_s) is the intersection of the row and column.
5. Multiply the allowable load by the applicable load adjustment factor.
6. Reduction factors for multiple edges or spacing are multiplied together.

Edge Distance Tension (f_c)



Edge Dist. C_{act} (in)	Size	1/4	5/16	3/8	1/2	5/8	3/4
	C_{cr}	2 1/2	3 1/8	3 3/4	5	6 1/4	7 1/2
	C_{min}	1 1/4	1 9/16	1 7/8	2 1/2	3 1/8	3 3/4
	f_{cmin}	0.60	0.60	0.60	0.60	0.60	0.60
1 1/4		0.60					
1 1/2		0.68					
1 9/16		0.70	0.60				
1 7/8		0.80	0.68	0.60			
2		0.84	0.71	0.63			
2 1/2		1.00	0.84	0.73	0.60		
3			0.97	0.84	0.68		
3 1/8			1.00	0.87	0.70	0.60	
3 1/2				0.95	0.76	0.65	
3 3/4				1.00	0.80	0.68	0.60
4					0.84	0.71	0.63
4 1/2					0.92	0.78	0.68
5					1.00	0.84	0.73
5 1/2						0.90	0.79
6						0.97	0.84
6 1/4						1.00	0.87
6 1/2							0.89
7							0.95
7 1/2							1.00

*See page 7 for an explanation of the load table icons

Spacing Tension and Shear (f_s)

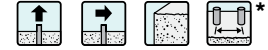

S_{act} (in)	Size	1/4	5/16	3/8	1/2	5/8	3/4
	Embed	1 1/8	1 7/16	1 1/2	2 1/4	2 3/4	3 3/8
	S_{cr}	4 1/2	5 3/4	6	9	11	13 1/2
	S_{min}	2 1/4	2 7/8	3	4 1/2	5 1/2	6 3/4
	f_{smin}	0.50	0.50	0.50	0.50	0.50	0.50
2 1/4		0.50					
2 1/2		0.56					
2 7/8		0.64	0.50				
3		0.67	0.52	0.50			
3 1/2		0.78	0.61	0.58			
4		0.89	0.70	0.67			
4 1/2		1.00	0.78	0.75	0.50		
5			0.87	0.83	0.56		
5 1/2			0.96	0.92	0.61	0.50	
5 3/4			1.00	0.96	0.64	0.52	
6				1.00	0.67	0.55	
6 1/2					0.72	0.59	
6 3/4					0.75	0.61	0.50
7					0.78	0.64	0.52
8					0.89	0.73	0.59
9					1.00	0.82	0.67
10						0.91	0.74
11						1.00	0.81
12							0.89
13							0.96
13 1/2							1.00

1. S_{act} = actual spacing distance at which anchors are installed (inches).
2. S_{cr} = critical spacing distance for 100% load (inches).
3. S_{min} = minimum spacing distance for reduced load (inches).
4. f_s = adjustment factor for allowable load at actual spacing distance.
5. f_{scr} = adjustment factor for allowable load at critical spacing distance. f_{scr} is always = 1.00.
6. f_{smin} = adjustment factor for allowable load at minimum spacing distance.
7. $f_s = f_{smin} + [(1 - f_{smin})(S_{act} - S_{min}) / (S_{cr} - S_{min})]$.

See Notes Below

Edge Distance Shear (f_c)



Edge Dist. C_{act} (in)	Size	1/4	5/16	3/8	1/2	5/8	3/4
	C_{cr}	2 1/2	3 1/8	3 3/4	5	6 1/4	7 1/2
	C_{min}	1 1/4	1 9/16	1 7/8	2 1/2	3 1/8	3 3/4
	f_{cmin}	0.30	0.30	0.30	0.30	0.30	0.30
1 1/4		0.30					
1 1/2		0.44					
1 9/16		0.48	0.30				
1 7/8		0.65	0.44	0.30			
2		0.72	0.50	0.35			
2 1/2		1.00	0.72	0.53	0.30		
3			0.94	0.72	0.44		
3 1/8			1.00	0.77	0.48	0.30	
3 1/2				0.91	0.58	0.38	
3 3/4				1.00	0.65	0.44	0.30
4					0.72	0.50	0.35
4 1/2					0.86	0.61	0.44
5					1.00	0.72	0.53
5 1/2						0.83	0.63
6						0.94	0.72
6 1/4						1.00	0.77
6 1/2							0.81
7							0.91
7 1/2							1.00

1. C_{act} = actual edge distance at which anchor is installed (inches).
2. C_{cr} = critical edge distance for 100% load (inches).
3. C_{min} = minimum edge distance for reduced load (inches).
4. f_c = adjustment factor for allowable load at actual edge distance.
5. f_{ocr} = adjustment factor for allowable load at critical edge distance. f_{ocr} is always = 1.00.
6. f_{cmin} = adjustment factor for allowable load at minimum edge distance.
7. $f_c = f_{cmin} + [(1 - f_{cmin})(C_{act} - C_{min}) / (C_{cr} - C_{min})]$.